



NICE HSCU2W, HSCU2C, HSCU2GW, HSCU2GC

Setting up the system components for configuration:

Since the system components communicate wirelessly, it is best to configure the system first on the bench and only then locate and install the devices. For control panels which also have electrical connections, proceed as follows:

- 1) configure the wireless devices on the bench;
- 2) mount all devices;
- 3) make the electrical hookup. To avoid errors, malfunctions and reception failures, proceed as follows:
 - a) Place all products on the bench with their packaging open;
 - b) Insert the "SIM" card for the GSM version (see figure 10); Caution - the SIM card's PIN must be cancelled, along with any messages, contacts and other resident or saved information. Caution - 3G SIM cards are not compatible.
 - c) Power up the control panel and program it - "Alarm system programming";
 - d) Insert the batteries into the devices so that the control panel can acquire them one by one;
 - e) Test the operation of the various devices;
 - f) Place the control panel in its intended location (do not mount it there yet);
 - g) Place the other devices in their intended positions (again, without mounting them yet);
 - h) Check that every device has sufficiently wireless reception to operate (see "Testing the control panel"); In GSM models, check that there is sufficient reception:
 - i) Now install all devices in place; The following paragraphs describe the installation of the control panel (all models) and the electrical hookup of wired versions.

Preliminary checks before installation and limitations on use:

Before proceeding with installation, check the condition of the product, suitability of the selected model and conditions of the intended installation environment.

- Check that all conditions fall within the "limits of use" and "technical characteristics".
- Check that the installation location is compatible with the overall clearance of the product.
- Check that the mounting surface is solid, so that the device is mounted securely and is protected against impact.
- Install the control panel at least 1 m off the ground. • the product may only be used with Nice Home Security system devices

Installation:

All control panel models are fitted with system memory boards.

During programming, the card stores the system parameters (excluding voice messages recorded by the installer or user) and can be transferred from one control panel to another. Before removing or inserting the board make sure that the control panel is off and not powered. Some control panel models (models HSCU2GC and HSCU2G) are equipped with a GSM telephone dialler. The SIM card must be inserted before starting installation and with the power off. The SIM card may be provided by any cellular operator and with any contract (the system only uses the voice and SMS services), but must be configured with PIN code = "1234" or set as "access without PIN": this can be done by inserting the SIM card in any GSM phone.

Caution! – For HSCU2GC and HSCU2GW: do not crush or bend the GSM antenna cable

01. Open the container, and remove the protective mask (fig. 7-A) and then the cover (fig. 7-B);
02. Release the side hook to rotate the control panel's: see fig. 8 per mod. HSCU2C and HSCU2W - see fig. 8A for mod. HSCU2GC and HSCU2GW;
03. Ensure that the memory board is correctly inserted in the internal connector guides (fig. 9). In control panel models HSCU2GC and HSCU2G (with GSM), also insert the SIM card (fig. 10);
04. Before securing the container, you can activate the blade proofing system on the rear tamper (fig. 11): a) remove part "a" as shown and set it aside b) remove part "b" as shown and discard it;
05. For models HSCU2GC and HSCU2C: set up the cable hole (fig. 12) and run the power cables through it (fig. 13);
06. Restore the control panel body to its holder (fig. 14);
07. Mark on the wall the 3 mounting points indicated in fig. 15 and the bladeproofing system hole indicated as detail "a" (fig. 15);
08. Drill the wall at the 3 marked points and insert the provided wall plugs (fig. 16). For the bladeproofing system, drill the 4th hole and fit the anchor plug and part "a" previously set aside (fig. 16);
09. Fix the control panel to the wall with the provided screws (fig. 17);
10. Electrical connections: • For models HSCU2GC and HSCU2C: make the electrical connections and insert the backup battery with reference to chapter 5. • For models HSCU2W and HSCU2GW: connect the battery (battery pack) as shown in fig. 18;
11. Close the container (fig. 19);
12. Now install the various devices and program the control panel

ELECTRICAL CONNECTIONS:

The mains power hookup must be done by a qualified electrician in line with electrical equipment regulations.

Control panel connections (models HSCU2GC and HSCU2C only)

Caution! – Before opening the control panel's enclosure, disconnect it from the mains power supply.

01. To hook up the power cable, insert the ferrite cylinder as shown in fig. 20 and position it as shown in fig. 21; Warnings: - To facilitate the connections to the terminal clamps, depress the release button. - The wires must be secured by closing the terminal cover with its screw;
02. For the electrical connections to the terminal block, refer to Table 4;
03. To insert the backup battery (not included) refer to fig. 22; 04. Once the connections have been completed, close the internal cover and only then close the circuit breaker or insert the mains plug

Connections on the HSSOC siren:

To connect the siren with the control panel, refer to Table 4 and figure 27A if the inputs are set as N.C. or 27B if the inputs are set as balanced

Telephone line connection:

Connect the phone line to connector (b) on the control panel, see fig. 6A and 6B on page 11. * Note (fig. 23 and 24) - The adapters are not included. In case of other devices connected to the telephone line, follow the order specified in fig. 23. Important! - If an ADSL is used, a special filter must be used (not provided), which must be installed between the telephone socket and the control panel, see fig. 24.

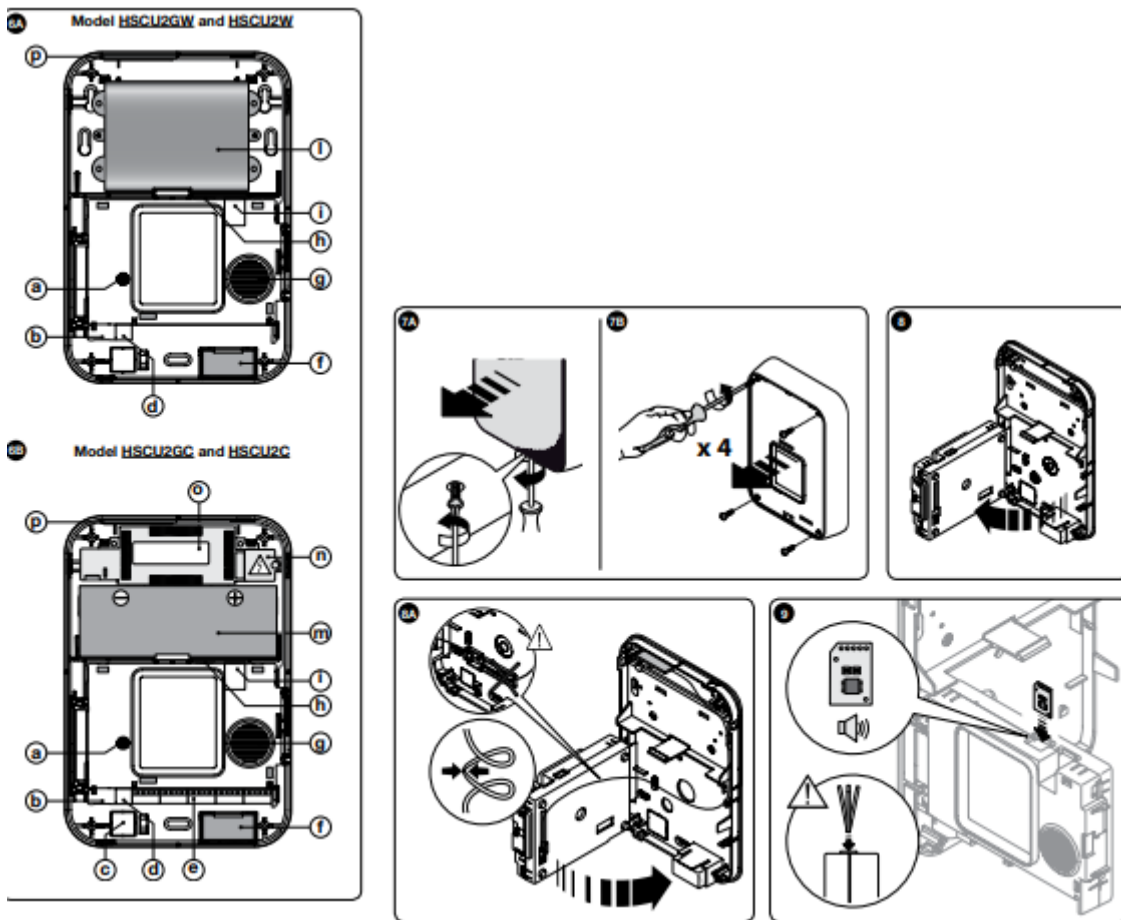

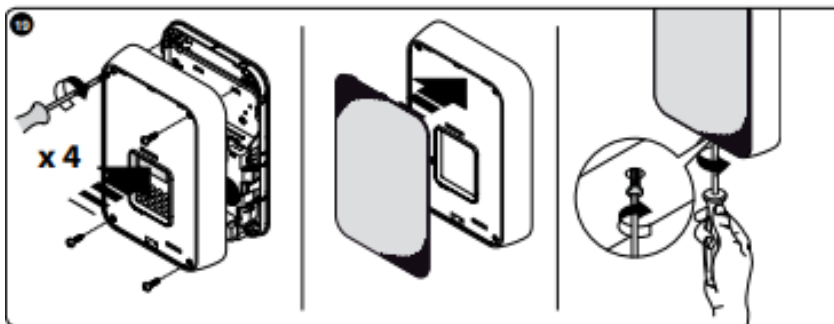
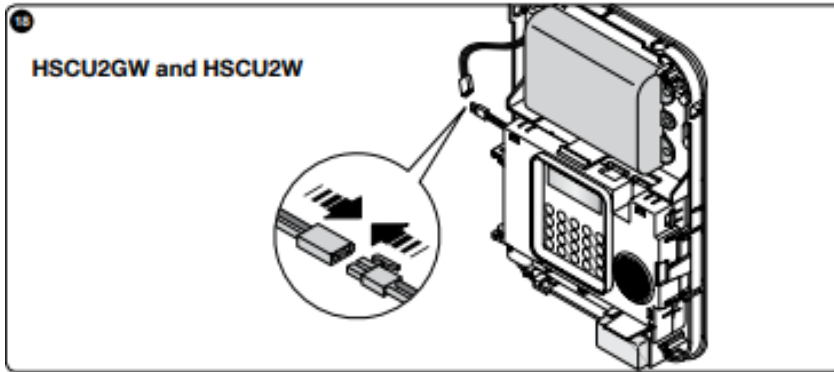
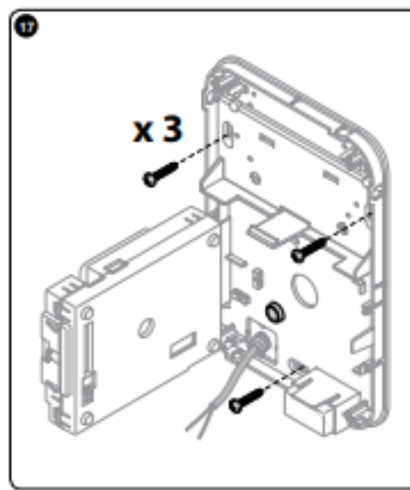
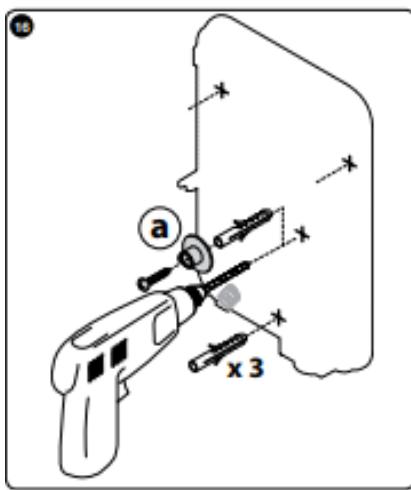

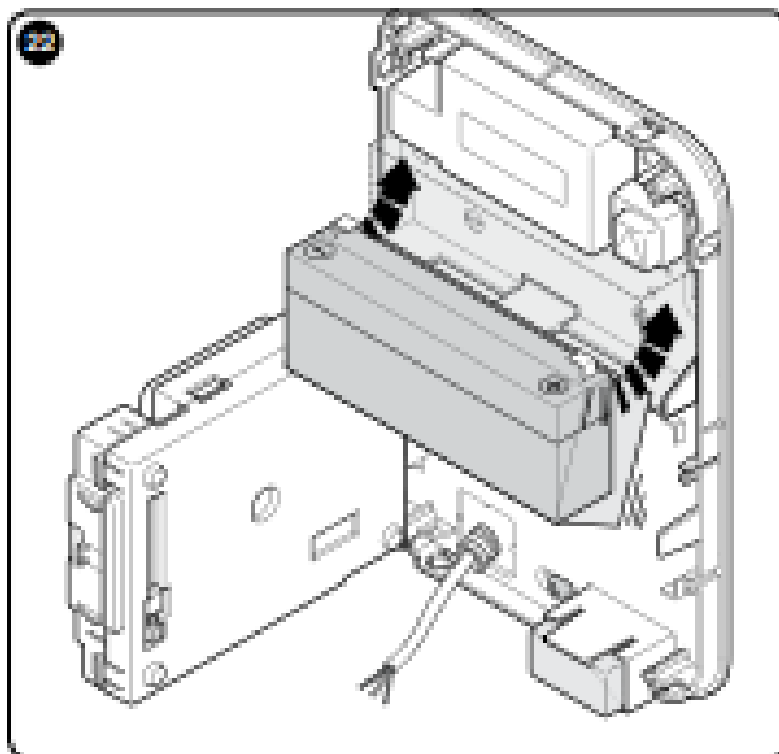
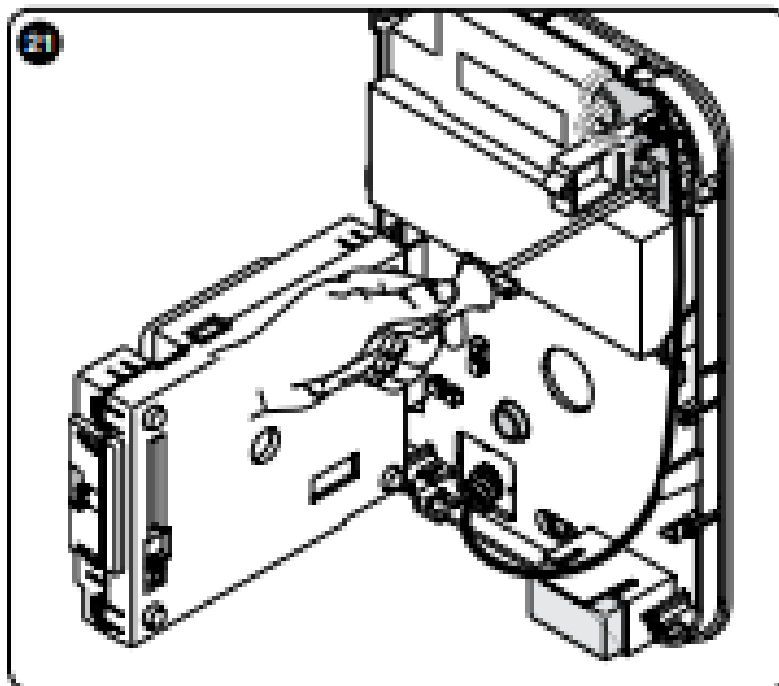
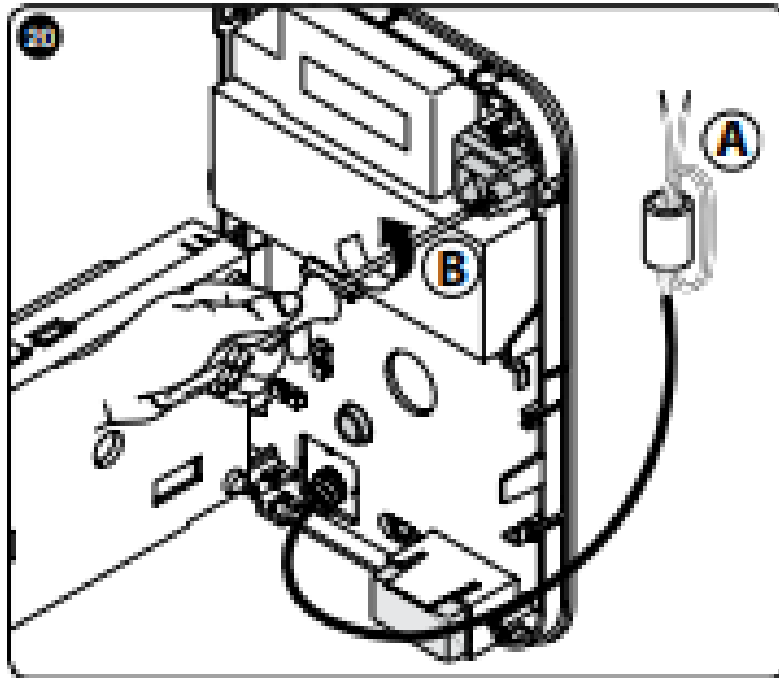

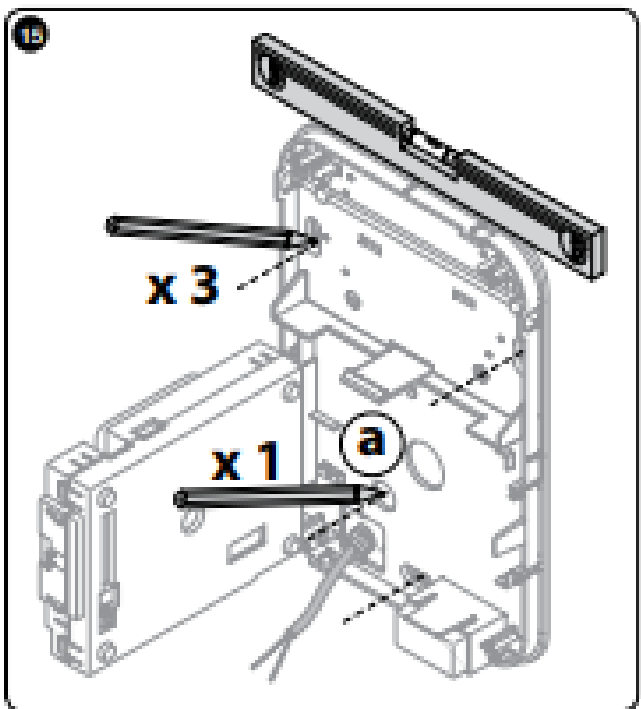
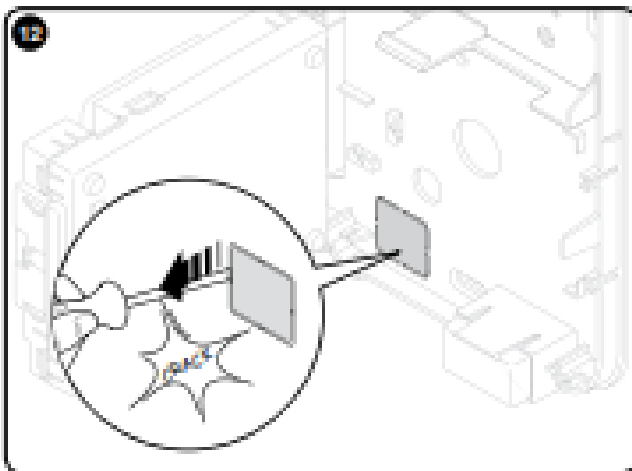
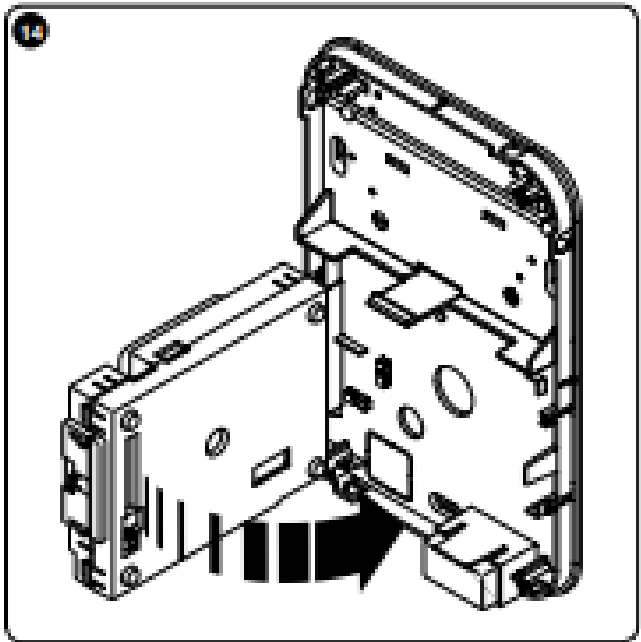
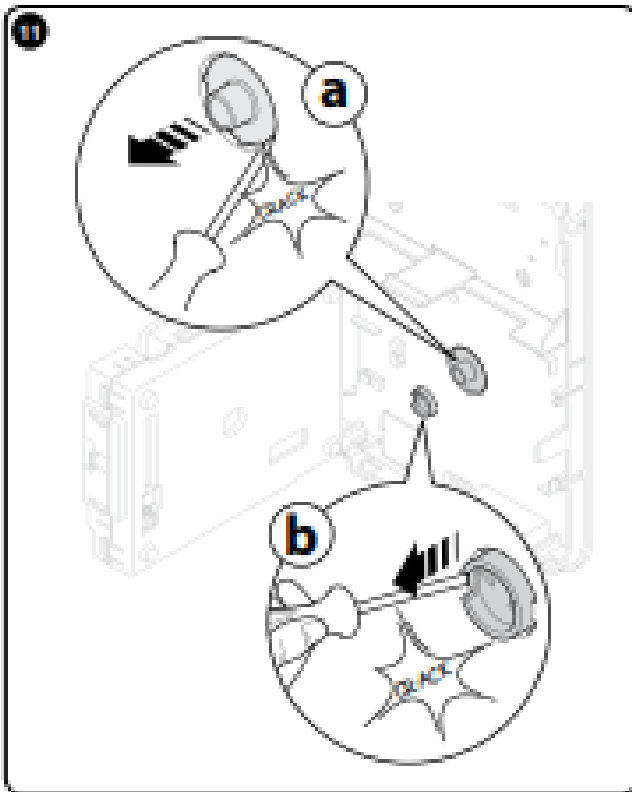
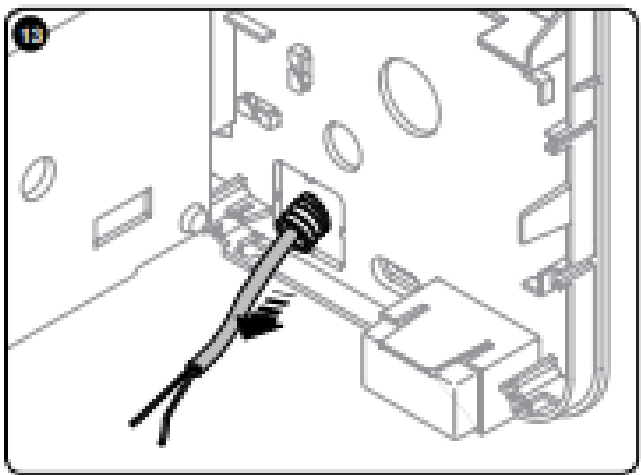
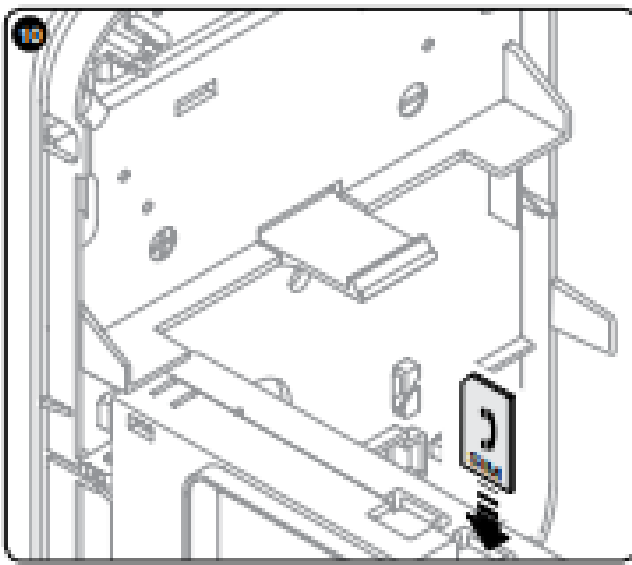

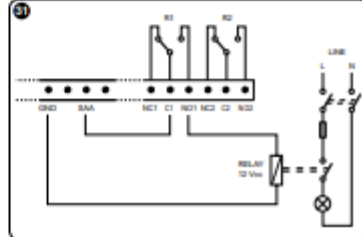
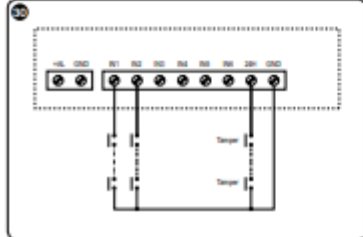
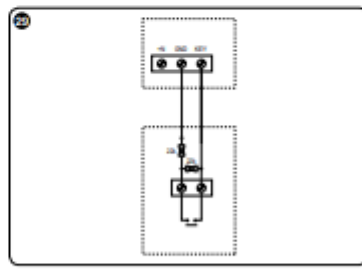
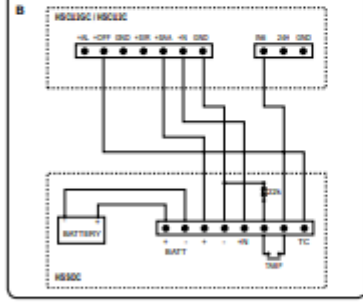
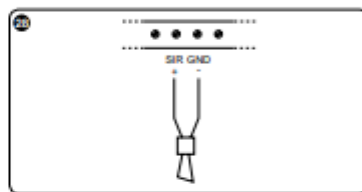
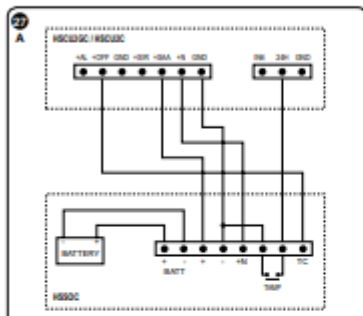
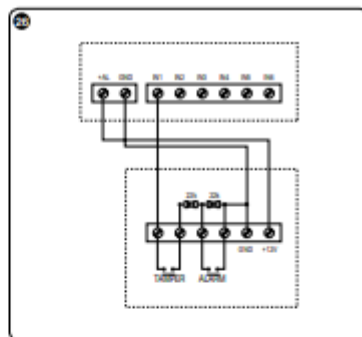
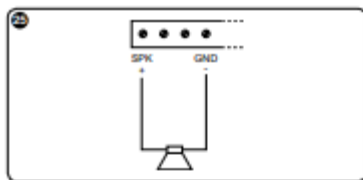
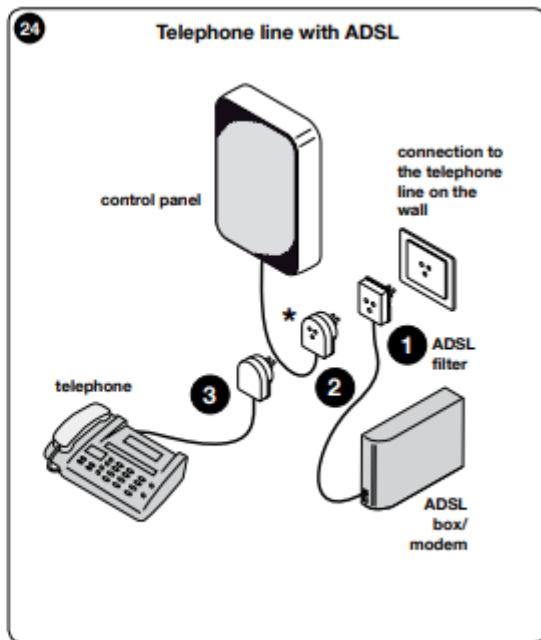
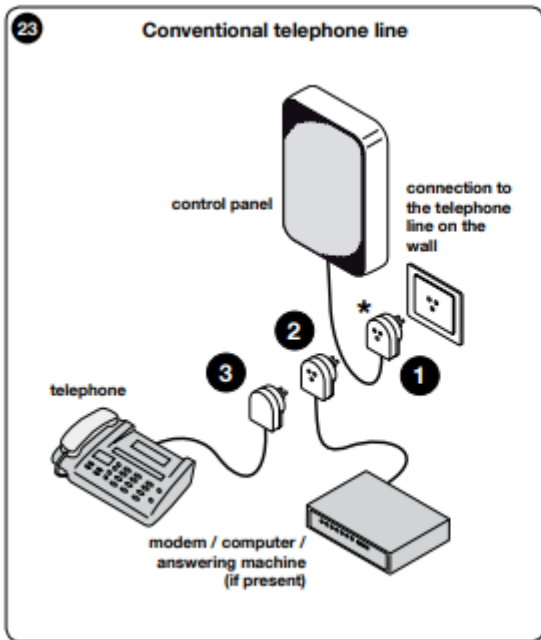

TABLE 4 - description of electrical connections

| OUTPUT | DESCRIPTION |
|------------|---|
| SPK | External speaker positive output (8 Ω). Intended for a supplementary speaker for the control panel's voice messages; see fig. 25 |
| + ALI | Constant positive, for power to wired detectors; 12 V DC max. 500 mA; see fig. 26 |
| + OFF | Positive when the control panel is powered off, blocks wired sirens; see fig. 27 |
| GND (all) | Negative for all connections |
| + SIR | Positive when alarm is tripped, for supplementary sirens, 12 V DC max. 500 mA; see fig. 28 |
| + SAA | Positive (14 V DC), for wired siren battery charger (not available if mains power is not present; see fig. 27) |
| + N | Caution! – If 2 sirens are hooked up, you must fit 2 diodes to the clamp to prevent return signals. Caution! – Never use this output for powering the sirens |
| KEY | ON-OFF double balanced output for external key (closed = OFF); see fig. 29 |
| IN1..IN6 | Alarm inputs; see fig. 30 |
| 24H | Double balanced fault input with EN50131 enabled (Y). With EN50131 disabled (N) it becomes an NC tamperproofing contact; see fig. 30 and 27A |
| NC1-C1-NO1 | R1 relay output, 12V max. 500mA (connect only to SELV circuits); see fig. 31 |
| NC2-C2-NO2 | R2 relay output, 12V max. 500mA (connect only to SELV circuits); see fig. 31 |
| PHONE | PSTN phone line connection; see fig. 6 |
| PC | PC connection (requires USB interface); see fig. 6 |

Notes: • The alarm and tamper inputs are enabled when first closed. If they are closed by mistake, they report an alarm. To reset the signal, enable/disable CONTROL PANEL TEST mode.

PROGRAMMING THE ALARM SYSTEM:

Assigning the HSTS2 touch screen to the HSCU2 control panel

Before programming all devices, you must first program the HSTS2 touch screen keypad and assign it to the HSCU2 control panel. Note – Place the control panel and other devices on a table without their batteries

Assigning the HSTS2 touch screen keypad to the control panel

For the HSTS2 to communicate with the HSCU2 control panel, it must be assigned to it as follows:

- 01. Invent Installer and User codes (4 to 8 digits) and enter them in the following table. Important! – The codes must be different.

Definition of the three types of code

Installer code: This code is a sequence of 4 - 8 digits which gives access to programming functions with the installer's permissions. Normally, the installer programs and configures the alarm system; he has access to all programming functions, including system reset, but cannot arm or disarm the alarm.

User code: – This code is a sequence of 4 - 8 digits which gives access to selected programming functions. Normally, the user operates the system day to day (e.g., reads the event log, switches off a detector for a period of time, etc.). The user code allows you to arm and disarm the system.

Access codes – These are 5 digit sequences which only allow you to arm/ disarm the alarm system.

The access codes are usually assigned, – one per person, – to persons you wish to be able to arm and disarm the alarm system. It is best not to assign a single code to multiple users, otherwise it is hard to see who has been operating the system from the event list.

Programming the HSCU2 alarm control panel:

Access to the programming menu:

01. In the main menu, touch "Alarms"
02. . Make sure the alarm system is disarmed. If it is not, ask the user to disarm it.
03. 03. Scroll vertically with the arrows and select "Menu"
04. 04. a) With EN 50131 disabled (first installation): enter the "Installer code" (this must already have been programmed).
05. With EN50131 enabled: Enter the "User code", scroll through the menu and select "Installer code" and enter the installer code in the following page.
06. 05. Confirm with "OK". 06.