

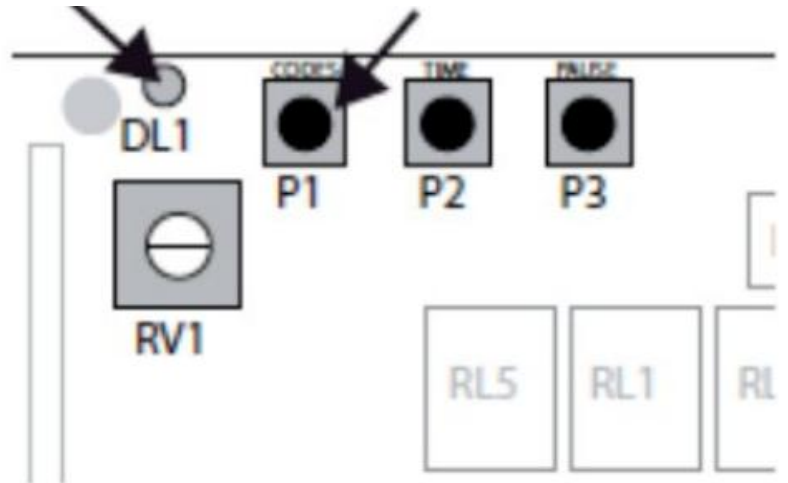

SENTINEL SCS SG and SCS



1. Take your remote control, open the control unit and locate the button P1 and the LED DL1
2. Press the button P1 and release it. The DL1 LED will flash, comes off and then flash again
3. While DL1 is flashing, press button 1 of your remote control
4. The LED will come off
5. Your new remote control is now programmed